

Certain zoning requirements must be met to obtain a building permit to construct an enclosed vestibule, unenclosed porch, or other projections. The zoning envelope, the area that is required, for front, side and rear yards on residential lots, varies among the separate zoning categories in the City of Toledo. Minimums are established by the zoning board to allow space between houses for both privacy and aesthetics.

Enclosed vestibules are limited in size to a maximum of 40 square feet and a maximum 4 foot projection when built on the front of a house and extending into the required front yard.

Unenclosed porches or fixed awning may extend a maximum of 10 feet from the structure into required front and rear yards. In side yards, they are limited to extending a maximum of 3 feet into the required side yard.

Decks, terraces, or uncovered porches which do not extend more than 3 feet above the ground may project into a required yard, providing they are at least 2 feet from the side lot lines.

Overhangs on one-story buildings are limited to 12 inches or less, and on two story buildings 24 inches or less. Patios and terraces do not require a permit if there is no footer or structure involved. As always residents should check their deed for restrictions and easements.

ALLOWABLE PROJECTIONS IN REQUIRED FRONT YARDS

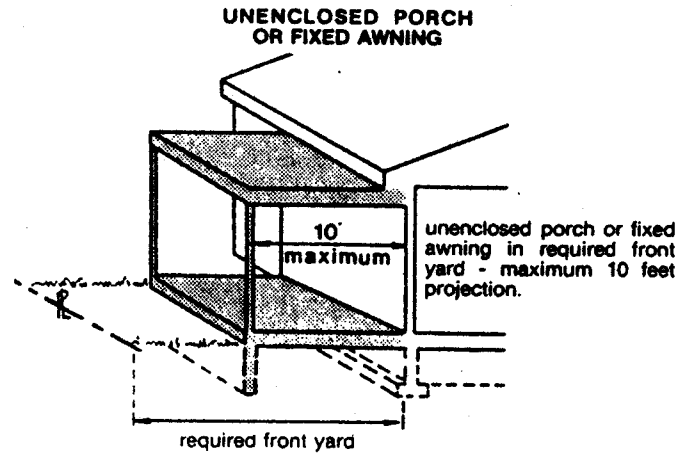
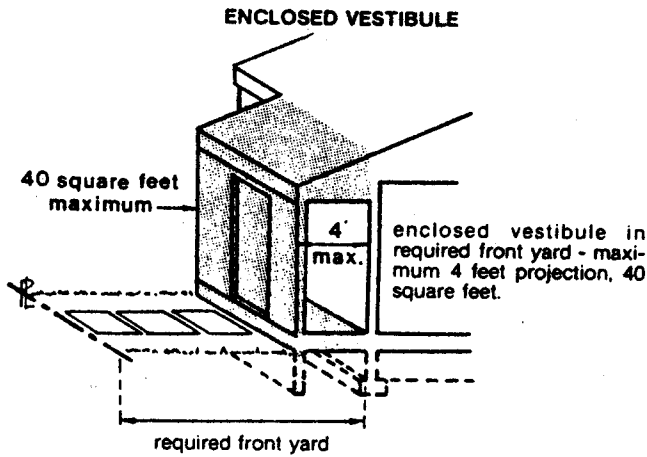

ALLOWABLE PROJECTIONS IN REQUIRED SIDE YARDS

UNENCLOSED PORCH OR FIXED AWNING

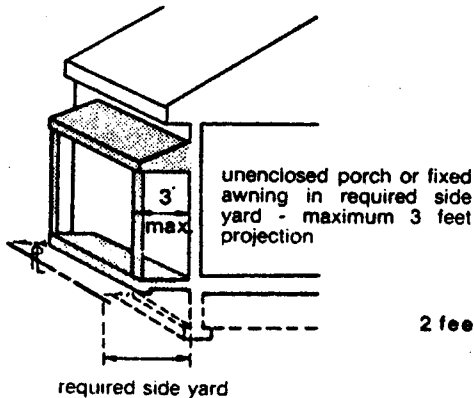

DECKS, TERRACES, OR UNCOVERED PORCHES

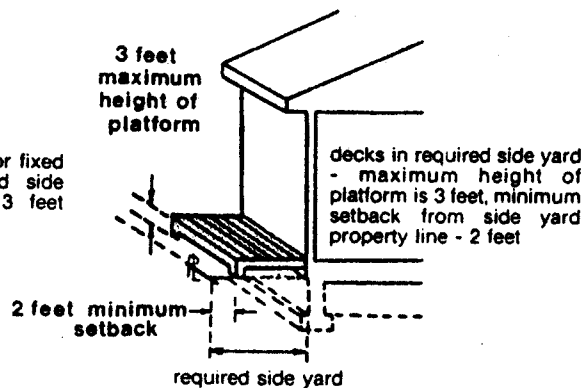

OVERHANGS

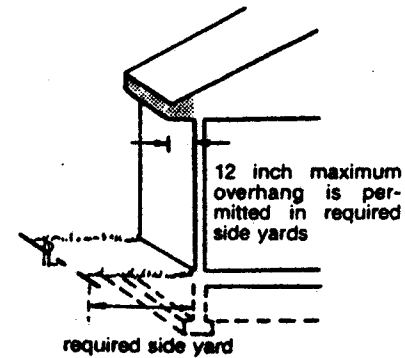

Gutters and downspouts are required when overhang is 12 inches or less on 1-story buildings, and 24 inches or less for 2-story buildings.